



Machine Aim Cards

Water a plant.

Run a bath.

Make a drink.

Hang a coat up.

Pack a bag.

Tie a pair of
shoelaces.

Put toothpaste on
a toothbrush.

Turn a light off.

Find a
missing pen lid.

Tidy a table.

Collect mail from
the letterbox.

Tie a tie.

Make a bed.

Peel an apple.

Set a table.

Write a card.



Marvellous Machines

Design your marvellous machine in the box below.

Machine Name:

What is your machine's aim?



How does your machine work?

Firstly: _____

Then: _____

Next: _____

Finally: _____

Your partner should write in this section to evaluate your machine and your explanation of how it works.

Use these words to help you explain and evaluate the machine.

pulley lever gear move pull push lift speed slow fast force spin turn around

Marvellous Machines

Design your marvellous machine in the box below.



Machine Name:

What is your machine's aim?



How does your machine work?



Your partner should write in this section to evaluate your machine and your explanation of how it works.



Mechanism Facts

Pulleys can be used to make a small force lift a larger load.

A pulley is a wheel or a collection of wheels over which a rope is looped.

A pulley with a single wheel and a rope helps you change the direction of the lifting force. To lift the weight, you pull the rope downwards.

The more wheels a pulley has, the more it reduces the force needed to lift the weight. With two wheels, you can lift the weight using half as much force. With four wheels, you can lift the weight using only a quarter as much force!

The more wheels you have in the pulley, the longer rope you need. So, even though you reduce the amount of force you need to use to lift the weight, you have to apply the force over a longer period of time as you pull the longer rope.





Gears or cogs can be used to change the speed, force or direction of motion.

Gears are wheels with teeth, or indentations, which lock together and turn one another.

If you connect two gears together, and the first gear is larger than the second, the second gear will turn much faster than the first. This way you can increase the speed of the motion.

If the second wheel in a pair of gears is larger, it will turn much more slowly than the first, but with more force.

When two gears are connected, they always turn in opposite directions to each other. This is how gears can change the direction of motion.

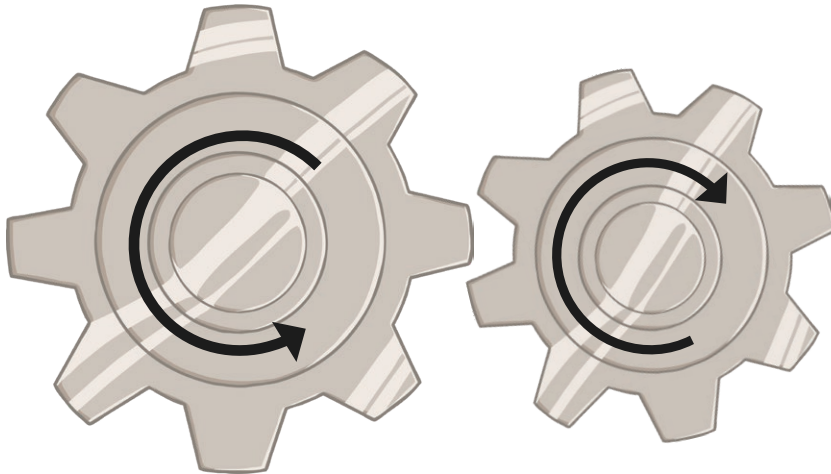



Levers can be used to make a small force lift a larger load.

A lever always rests on a pivot.

A lever has three parts – the place where you apply a pushing or pulling force, the point where it pivots and the place where the work, usually lifting, is done.

The distance between the pivot and the place where the person pushes affects how easy or hard it is to lift a load with the lever.

Levers were used in ancient Egypt to lift stones to construct the pyramids.



Mechanisms Jigsaw

Levers

Pulleys

Gears or cogs